



# HPS TruWave<sup>®</sup>

Active Harmonic Filter



ODVA Declaration of Conformity



HPS TruWave™ active harmonic filter (AHF) is a comprehensive and flexible solution for harmonic mitigation. It provides the advanced control and proven reliability that your facility needs to solve power quality issues.

It monitors the load current and very quickly responds to the power system distortion as it develops. A corrective current is injected to effectively cancel out the harmonics required from the upstream power source. The result is a harmonic load on the power system that is acceptable, with more balanced current and voltage waveforms.

HPS TruWave operates at one of the highest efficiencies for any AHF, ensuring that losses are minimized. HPS TruWave is a critical addition to any plant or facility requiring IEEE-519 compliance.



## Power Quality & Harmonic Distortion

Power quality problems are one of the major causes of unscheduled down time, equipment malfunction and damage. The majority of power quality issues are a result of harmonic distortion.

Causes: Non-linear loads such as variable frequency drives (VFDs), DC drives and induction heating systems.

- Consequences:
- Overheating of electrical equipment
- Loss of efficiency
- Nuisance tripping
- Premature equipment failure
- Interference with communication systems

## Power Quality & Harmonic Distortion Solution

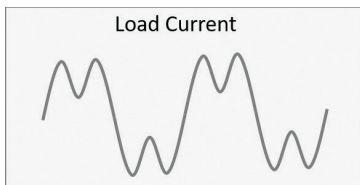

Current harmonics generated by VFDs.

+

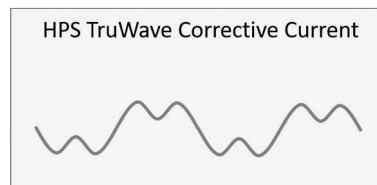

Corrective current injected by Active Filter

=

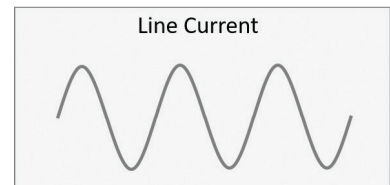

Line current with a minimum power losses and disturbances seen by power system

# HPS TruWave Operation Principle

Each AHF unit is connected in parallel with non-linear loads that require harmonic compensation. The current sensors placed on the bus are continuously monitoring the load harmonics. The switching devices (IGBTs) inside the AHF unit inject the corrective currents to cancel out harmonic currents generated by non-linear loads. The result is an ideal line current with minimum power losses and disturbances seen by the transformer.

## Example Installation

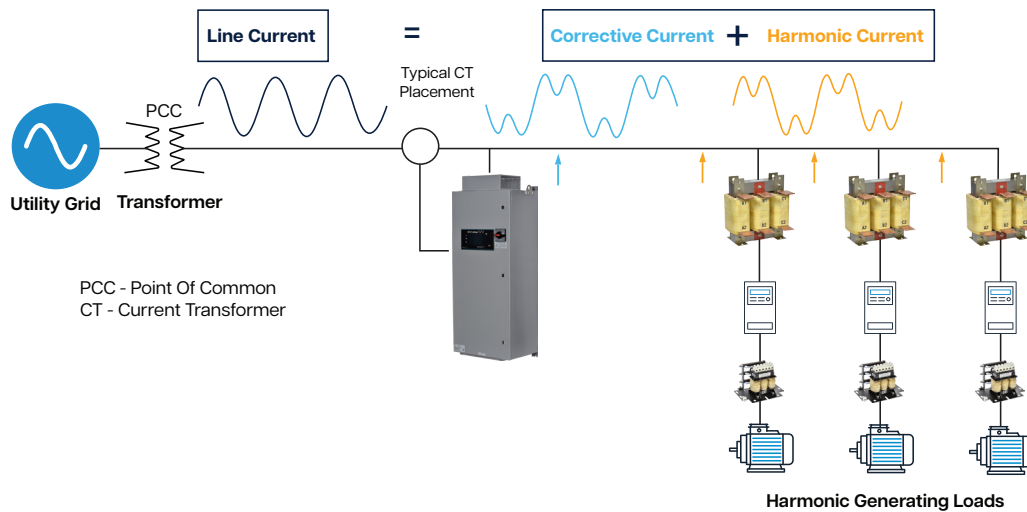

## What You Gain

Compared to other power quality technologies HPS TruWave provides an efficient and reliable solution.



### Profitability

Active harmonic filters are the world's most flexible solution for power quality issues.



### Improved Reliability

Increased electrical power quality results in increased uptime and reduces nuisance tripping events



### Energy Savings

Combine the most efficient active harmonic filters with proven system efficiency gains.



### Advance Remote Management

Scaling of different size CTs is accomplished with front LCD touchscreen.

## Applications

Critical applications require IEEE-519 compliant power systems. Below are some examples of industries with critical applications:

- Chemical Processing
- Data Centers
- HVAC Systems
- Material Handling
- Mining
- Oil & Gas
- Pulp & Paper
- Hospitals
- Wastewater Treatment Plants
- EV Charging



## Power Quality & Harmonic Distortion

The HPS TruWave™ is a true Active Filter and is a comprehensive solution for harmonic mitigation and power factor correction.

- Actively reduces harmonic distortion to below 5% complying with IEEE-519 recommendation
- Improves power factor resulting in decreased utility cost
- Parallel system installation to accommodate large scale applications
- 98% operation efficiency to lower operational costs and increased reliability
- Balances three phase loads for increased usable system capacity
- Corrects for single/multiple loads enabling cost effective solutions



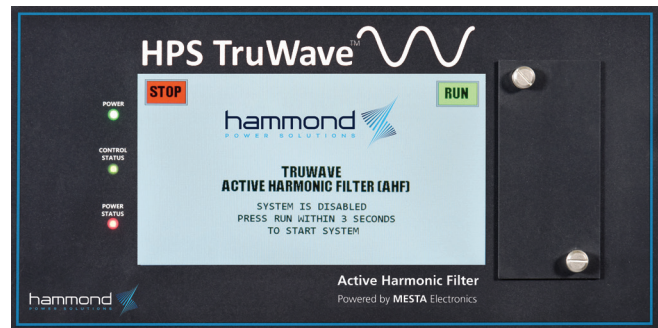

## Advanced LCD Touchscreen Display

- Detailed power quality information for evaluation of the effectiveness of the system
- Detailed historical data
- FDR data information
- LED indicators
- Firmware update via front panel interface with flash drive
- Troubleshooting via the front display, serially over ethernet, or using flash drive
- Easy access to ethernet communication interface
- CT diagnostic and auto-correction

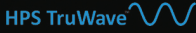

## Active Harmonic Filter Sizing Tool

HPS TruWave™ AHF can be sized using an Excel-based program. It uses your basic system data to generate accurate harmonic and power quality analysis to select the HPS TruWave unit for your unique applications.

ACTIVE HARMONIC FILTER SIZING

**CUSTOMER INPUT**

Non-Linear Loads

Total Non-Linear Loads HP: 480

% DC Bus Choke Reactance (Z<sub>DC</sub>): 4

% Input Line Reactance (Z<sub>LINE</sub>): 0.3

Acceptable TDD: 3

Acceptable Displacement PF: 0.95

Linear Loads

Total Linear Motor Loads HP: 0

Linear Motor Loads PF: 0

Resistive Loads kW: 0

Total Linear PF: 0.0000

Return Values from Table

I<sub>RMS</sub>: 105.547

TDD: 42.851

PF: 0.91167

kW: 79.999

kVA: 87.751

Calculate Filter Size

	SYSTEM w/HPS TruWave		
	SYSTEM w/o HPS TruWave	System with acceptable TDD	System with 0% TDD & acceptable PF
RMS Current	506.6256	466.2544865	466.6727589
Fundamental Current	465.6727589	465.6727589	465.6727589
Harmonic Current	199.2454338	23.2835734	0
TDD%	42.851	5	0
Reactive Current	208.184726	63.75262587	59.3487111
DPM Current	0	118.2617284	199.5454339
I <sub>L1</sub>	461.8753608	461.8753608	461.8753608
I <sub>L0</sub>	59.3487111	59.3487111	59.3487111
Power Factor	0.91167	0.990607864	0.99184535

Estimated Size of HPS TruWave

**199.55 amps**

Select appropriate HPS TruWave model based on this estimate.

Information presented here is for estimating purposes only and does not imply any guarantee of performance or results. The HPS TruWave may not operate properly if any power factor correction capacitors, or line input filters, are installed on the load side of the HPS TruWave current sensors. Consult factory for any questions regarding the presence of power factor correction capacitors, or line input filters, on your system. All non-linear loads must have an input line reactor (min. 3%) or a DC link choke (min. 4%) to achieve desired system performance. A THD (V) of less than 5% can be achieved if TDD (I) is less than 5%.

# SPECIFICATIONS



## ELECTRICAL PRODUCT CHARACTERISTICS

<b>Voltage Rating:</b>	208-480 VAC; +12%/-15% (600 VAC with the use of autotransformer) 3 phase, 3 wire, plus ground
<b>Current Rating:</b>	50A, 100A, 150A, 200A, 300A, 400A, 500A, 600A @208-480VAC (40A, 80A, 120A, 160A, 240A @600VAC)
<b>Frequency:</b>	50Hz or 60Hz, $\pm 5$ Hz

Please consult HPS for system configuration requiring 4 wire systems.

## TECHNICAL PRODUCT CHARACTERISTICS

<b>Harmonic Attenuation:</b>	< 5% TDD as per IEEE 519-2014 (typically requires either 3% line reactor or 4% DC choke)
<b>Harmonic Cancellation:</b>	2 <sup>nd</sup> to 51 <sup>st</sup>
<b>Power Factor:</b>	Up to 0.99 immediately upstream of installation point - may depend on system loading
<b>Efficiency:</b>	98% at full load (industry-leading)
<b>Control Scheme:</b>	Full spectrum cancellation
<b>Control Response Time:</b>	500 $\mu$ s (industry-leading)
<b>Overload Capability:</b>	300% peak, 100% RMS
<b>Display:</b>	6" by 3.5" dust tight graphic colour LCD touchscreen
<b>Operator Interface:</b>	HMI colour LCD touch screen
<b>Approval:</b>	UL & cUL* Listed UL File No: E253505

\* 400A-600A cUL pending

## ENVIRONMENTAL CONDITIONS

<b>Ambient Operating Temperature:</b>	0°C to 40°C
<b>Humidity:</b>	95% maximum non-condensating
<b>Altitude:</b>	$\leq$ 1000m, (derate 1% per 100m above)
<b>Storage Temperature:</b>	-20°C to +60°C
<b>Cooling Configuration:</b>	Internal forced air
<b>Enclosure Type:</b>	Open or Type 1
<b>Optional Seismic Compliance:</b>	IBC 2018 and ASCE 7-16 standards (SDS = 2.0, I <sub>p</sub> = 1.5, z/h = 1)

<b>Display Parameters:</b>	Power quality information, operating parameters, operational status
<b>Touchscreen Functions:</b>	Run, stop, menus, parameter set-up
<b>Communication Capability:</b>	Ethernet (optional Ethernet/IP and Modbus TCP)
<b>Parallel Operation:</b>	Up to 10 units per set of CT
<b>Protection Class:</b>	Class T fuses rated at 200,000 AIC

### Current Transformer (CT) Information: Required with AHF solution

<b>Current Transformer:</b>	5 A secondary; 400 Hz rated Accuracy: 1-4%
<b>Quantity of CT:</b>	2 for 3 phase loads (3 required when line to neutral single phase loads present)
<b>CT Position:</b>	Phase A and B of the incoming line (3 phase loads); Phase C (if single phase loads present)
<b>CT Programming:</b>	Via front LCD touch screen

## HPS TruWave Part Number Guide

### Example



Family				Generation	Voltage Rating	Current Rating	Filter Enclosure	Option Indicator <sup>1</sup>					
								Suffix					
W	A	H	F	1	K	1	0	0	F	E	6	P	1



Family	Generation	Current Rating	Communication Options
WAHF = TruWave Active Harmonic Filter Prefix	1 = 1 <sup>st</sup> Generation	050 = 50A	E = Ethernet <sup>2</sup>
	<b>Voltage Rating</b>	100 = 100A	I = Ethernet/IP
	D - 240V	150 = 150A	T = Modbus TCP
	K - 480V	200 = 200A	<b>Frequency Options</b>
U - 690V (future)	300 = 300A	400 = 400A	6 = 60Hz <sup>2</sup>
	500 = 500A	600 = 600A	5 = 50Hz
	<b>Filter Enclosure</b>		<b>Seismic Options</b>
	F = Open Frame		S = Seismic
	A = Type 1		<b>Voltage Options</b>
			B = 208V
			H = 400V
			P = 600V - Requires autotransformer. Used on system greater than 480V <sup>3</sup>
			1 = Autotransformer provided by HPS

<sup>1</sup> Options Indicator = Separate items that are either configured via software, factory installed or stand alone.  
<sup>2</sup> Default options - ignore if all following characters are default values.  
<sup>3</sup> 480V units can also be used up to 600V, with an autotransformer. The current rating at higher voltage will be derated.

## Support & Resources

No other transformer company can offer our service and quality in a full range of products.

- 
**Power Quality Lab**  
 HPS offer an in-person and virtual tours of our Power Quality Lab where we can demonstrate our broad range of power quality products.
- 
**Partner Support**  
 HPS is supported by a National Representative and Distributor network.
- 
**Power Quality Products**  
 We carry an extensive inventory of other power quality solutions including Harmonic Mitigating Transformers, Drive Isolation Transformers and Reactors.

- 
**Live Telephone Technical Support**  
 Our inside sales team is available to quickly answer your questions. They are technically trained and able to answer most questions right over the phone.
- 
**Online Training**  
 HPS Academy has many interactive training presentations on topics such as our products, company, regulations and so much more. Short quizzes are available to ensure participants understand the information presented. [www.hpsacademy.com](http://www.hpsacademy.com)
- 
**Technical Webinars**  
 HPS offers interactive webinar presentations to provide customers with detailed product solutions. To schedule a webinar email: [marketing@hammondpowersolutions.com](mailto:marketing@hammondpowersolutions.com)

# SELECTION TABLES

## 240V & 480V

### 240V SYSTEM VOLTAGE

### OPEN FRAME

60HZ

Rated Current	Catalog Number	Enclosure	Frame	Approx. Dimensions - Inches [mm]			Approx. Weight Lbs [kg]	Watts Losses (kW)	Mtg Type W - Wall F - Floor
				Width	Depth	Height			
50	WAHF1D050F	Open	WF1	16.90 [429.26]	12.70 [322.58]	45.00 [1143.00]	135.0 [61.0]	0.9	W
100	WAHF1D100F	Open	WF2	16.90 [429.26]	12.70 [322.58]	45.00 [1143.00]	175.0 [79.0]	1.7	W
150	WAHF1D150F	Open	WF3	22.00 [558.80]	13.70 [347.98]	54.00 [1371.60]	245.0 [110.0]	2.5	W
200	WAHF1D200F	Open	WF4	22.00 [558.80]	13.70 [347.98]	54.00 [1371.60]	280.0 [126.0]	3.3	W
300	WAHF1D300F	Open	WF5	27.00 [685.80]	13.70 [347.98]	56.00 [1422.40]	400.0 [180.0]	5.1	F

### 240V SYSTEM VOLTAGE

### TYPE 1

60HZ

Rated Current	Catalog Number	Enclosure	Frame	Approx. Dimensions - Inches [mm]			Approx. Weight Lbs [kg]	Watts Losses (kW)	Mtg Type W - Wall F - Floor
				Width	Depth	Height			
50	WAHF1D050A	Type 1	WA1	21.00 [533.40]	14.25 [361.95]	53.00 [1346.20]	230.0 [104.0]	0.9	W
100	WAHF1D100A	Type 1	WA1	21.00 [533.40]	14.25 [361.95]	53.00 [1346.20]	270.0 [122.0]	1.7	W
150	WAHF1D150A	Type 1	WA2	27.00 [685.80]	16.50 [419.10]	63.50 [1612.90]	440.0 [198.0]	2.5	W
200	WAHF1D200A	Type 1	WA2	27.00 [685.80]	16.50 [419.10]	63.50 [1612.90]	480.0 [216.0]	3.3	W
300	WAHF1D300A	Type 1	WA3	33.00 [838.20]	18.00 [457.20]	75.00 [1905.00]	630.0 [284.0]	5.1	F

### 480V SYSTEM VOLTAGE

### OPEN FRAME

60HZ

Rated Current	Catalog Number	Enclosure	Frame	Approx. Dimensions - Inches [mm]			Approx. Weight Lbs [kg]	Watts Losses (kW)	Mtg Type W - Wall F - Floor
				Width	Depth	Height			
50	WAHF1K050F	Open	WF1	16.90 [429.26]	12.70 [322.58]	45.00 [1143.00]	135.0 [61.0]	0.9	W
100	WAHF1K100F	Open	WF2	16.90 [429.26]	12.70 [322.58]	45.00 [1143.00]	175.0 [79.0]	1.7	W
150	WAHF1K150F	Open	WF3	22.00 [558.80]	13.70 [347.98]	54.00 [1371.60]	245.0 [110.0]	2.5	W
200	WAHF1K200F	Open	WF4	22.00 [558.80]	13.70 [347.98]	54.00 [1371.60]	280.0 [126.0]	3.3	W
300	WAHF1K300F	Open	WF5	27.00 [685.80]	13.70 [347.98]	56.00 [1422.40]	400.0 [180.0]	5.1	F
400	WAHF1K400F	Open	WF6	Consult Factory					
500	WAHF1K500F	Open	WF7	Consult Factory					
600	WAHF1K600F	Open	WF8	Consult Factory					

### 480V SYSTEM VOLTAGE

### TYPE 1

60HZ

Rated Current	Catalog Number	Enclosure	Frame	Approx. Dimensions - Inches [mm]			Approx. Weight Lbs [kg]	Watts Losses (kW)	Mtg Type W - Wall F - Floor
				Width	Depth	Height			
50	WAHF1K050A	Type 1	WA1	21.00 [533.40]	14.25 [361.95]	53.00 [1346.20]	230.0 [104.0]	0.9	W/F*
100	WAHF1K100A	Type 1	WA1	21.00 [533.40]	14.25 [361.95]	53.00 [1346.20]	270.0 [122.0]	1.7	W/F*
150	WAHF1K150A	Type 1	WA2	27.00 [685.80]	16.50 [419.10]	63.50 [1612.90]	440.0 [198.0]	2.5	W/F*
200	WAHF1K200A	Type 1	WA2	27.00 [685.80]	16.50 [419.10]	63.50 [1612.90]	480.0 [216.0]	3.3	W/F*
300	WAHF1K300A	Type 1	WA3	33.00 [838.20]	18.00 [457.20]	75.00 [1905.00]	630.0 [284.0]	5.1	F
400	WAHF1K400A	Type 1	WA4	50.00 [1270.00]	20.00 [508.00]	72.00 [1829.00]	965.0 [438.0]	6.6	F
500	WAHF1K500A	Type 1	WA5	60.00 [1524.00]	20.00 [508.00]	80.00 [2032.00]	1200.0 [544.00]	8.4	F
600	WAHF1K600A	Type 1	WA5	60.00 [1524.00]	20.00 [508.00]	80.00 [2032.00]	1315.0 [597.00]	10.2	F

\*Optional floor mount kits are available

# SELECTION TABLES

## 600V

### 600V Operation

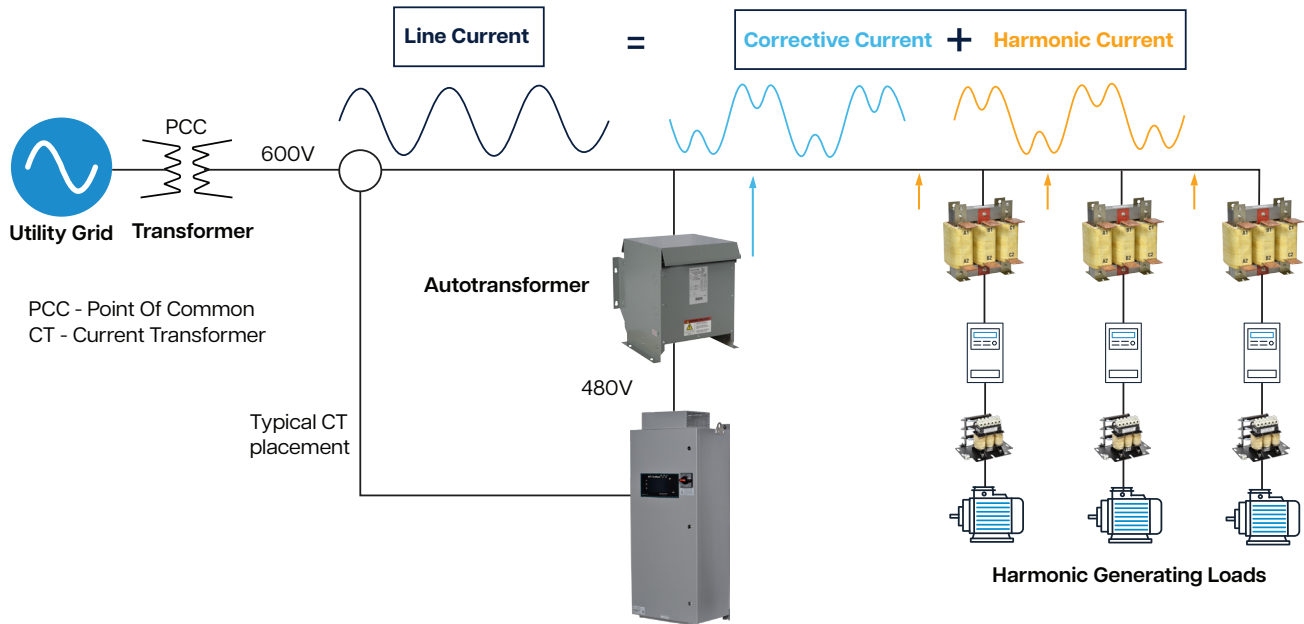

600V SYSTEM VOLTAGE (480V units with an autotransformer)

OPEN FRAME

60HZ

Rated Current with Autotransformer	Items Required	Enclosure	Frame	Approx. Dimensions - Inches [mm]			Approx. Weight Lbs [kg]
				Width	Depth	Height	
40	WAHF1K050F-E6P1	Open	WF1	16.90 [429.26]	12.70 [322.58]	45.00 [1143.00]	135.0 [61.0]
	Autotransformer	Type 3R	-	23.90 [607.06]	25.00 [635.00]	28.75 [730.25]	360.0 [162.0]
80	WAHF1K100F-E6P1	Open	WF2	16.90 [429.26]	12.70 [322.58]	45.00 [1143.00]	175.0 [79.0]
	Autotransformer	Type 3R	-	23.90 [607.06]	25.00 [635.00]	28.75 [730.25]	360.0 [162.0]
120	WAHF1K150F-E6P1	Open	WF3	22.00 [558.80]	13.70 [347.98]	54.00 [1371.60]	245.0 [110.0]
	Autotransformer	Type 3R	-	23.90 [607.06]	25.00 [635.00]	28.75 [730.25]	425.0 [191.0]
160	WAHF1K200F-E6P1	Open	WF4	22.00 [558.80]	13.70 [347.98]	54.00 [1371.60]	280.0 [126.0]
	Autotransformer	Type 3R	-	23.90 [607.06]	25.00 [635.00]	28.75 [730.25]	425.0 [191.0]
240	WAHF1K300F-E6P1	Open	WF5	27.00 [685.80]	13.70 [347.98]	56.00 [1422.40]	400.0 [180.0]
	Autotransformer	Type 3R	-	26.00 [660.40]	25.00 [635.00]	38.00 [965.20]	715.0 [322.0]

600V SYSTEM VOLTAGE (480V units with an autotransformer)

TYPE 1

60HZ

Rated Current with Autotransformer	Items Required	Enclosure	Frame	Approx. Dimensions - Inches [mm]			Approx. Weight Lbs [kg]
				Width	Depth	Height	
40	WAHF1K050A-E6P1	Type 1	WA1	21.00 [533.40]	14.25 [361.95]	53.00 [1346.20]	230.0 [104.0]
	Autotransformer	Type 3R	-	23.90 [607.06]	25.00 [635.00]	28.75 [730.25]	360.0 [162.0]
80	WAHF1K100A-E6P1	Type 1	WA1	21.00 [533.40]	14.25 [361.95]	53.00 [1346.20]	270.0 [122.0]
	Autotransformer	Type 3R	-	23.90 [607.06]	25.00 [635.00]	28.75 [730.25]	360.0 [162.0]
120	WAHF1K150A-E6P1	Type 1	WA2	27.00 [685.80]	16.50 [419.10]	63.50 [1612.90]	440.0 [198.0]
	Autotransformer	Type 3R	-	23.90 [607.06]	25.00 [635.00]	28.75 [730.25]	425.0 [191.0]
160	WAHF1K200A-E6P1	Type 1	WA2	27.00 [685.80]	16.50 [419.10]	63.50 [1612.90]	480.0 [216.0]
	Autotransformer	Type 3R	-	23.90 [607.06]	25.00 [635.00]	28.75 [730.25]	425.0 [191.0]
240	WAHF1K300A-E6P1	Type 1	WA3	33.00 [838.20]	18.00 [457.20]	75.00 [1905.00]	630.0 [284.0]
	Autotransformer	Type 3R	-	26.00 [660.40]	25.00 [635.00]	38.00 [965.20]	715.0 [322.0]

Figure 1

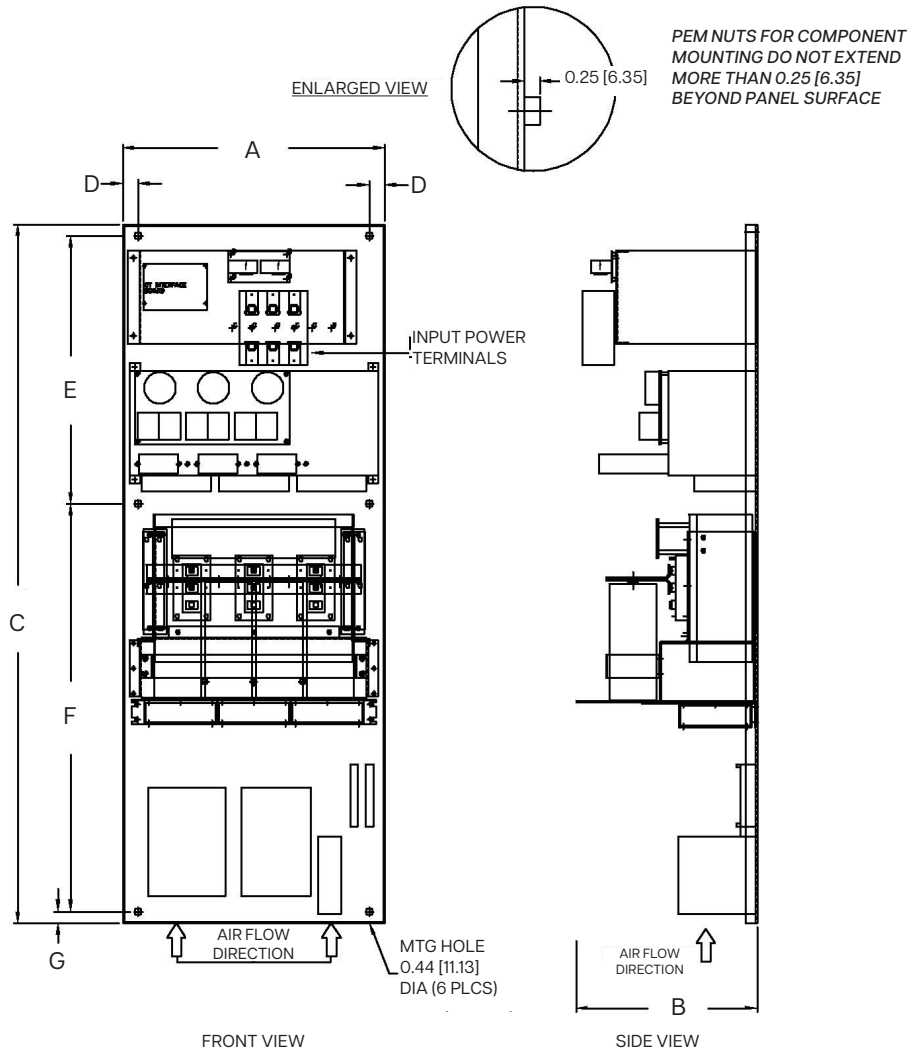

Panel Style	Fig. #	Dimensions in Inches [Millimeter]						
		A	B	C	D	E	F	G
WF1	1	16.90 [429.26]	11.70 [297.18]	45.00 [1143.00]	1.00 [25.40]	17.25 [438.15]	26.25 [666.75]	0.75 [19.05]
WF2	1	16.90 [429.26]	12.82 [325.63]	45.00 [1143.00]	1.00 [25.40]	17.25 [438.15]	26.25 [666.75]	0.75 [19.05]
WF3	1	22.00 [558.80]	12.54 [318.52]	54.00 [1371.60]	1.00 [25.40]	20.50 [520.70]	32.00 [812.80]	0.75 [19.05]
WF4	1	22.00 [558.80]	13.54 [343.92]	54.00 [1371.60]	1.00 [25.40]	20.50 [520.70]	32.00 [812.80]	0.75 [19.05]
WF5	1	27.00 [685.80]	13.56 [344.43]	56.00 [1422.40]	1.00 [25.40]	21.50 [546.10]	32.50 [825.50]	1.00 [25.40]

Figure WA1

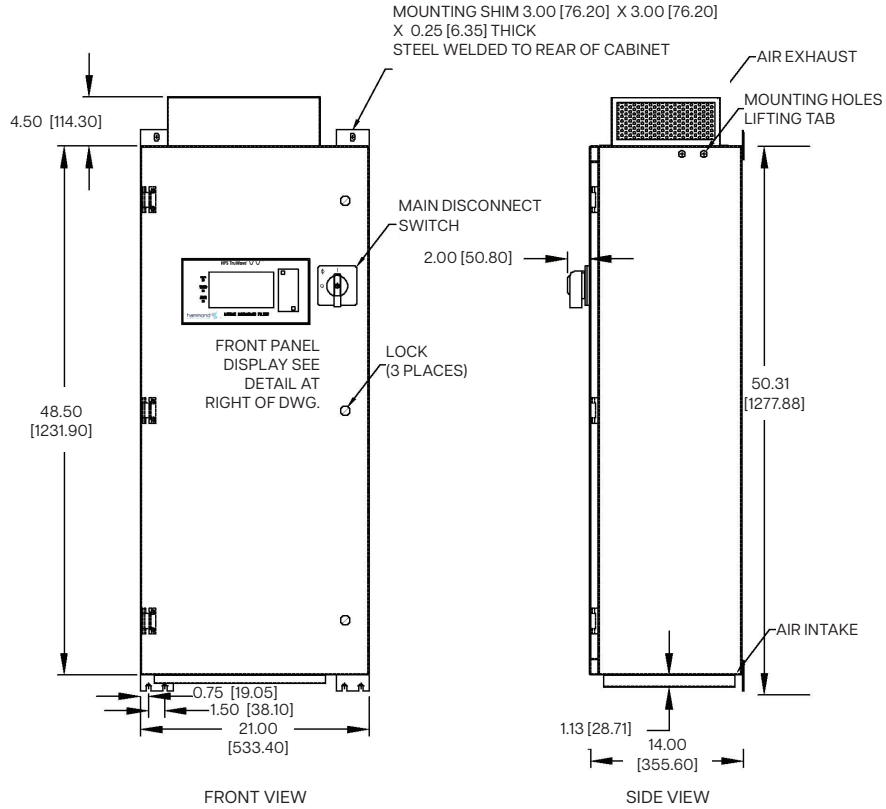
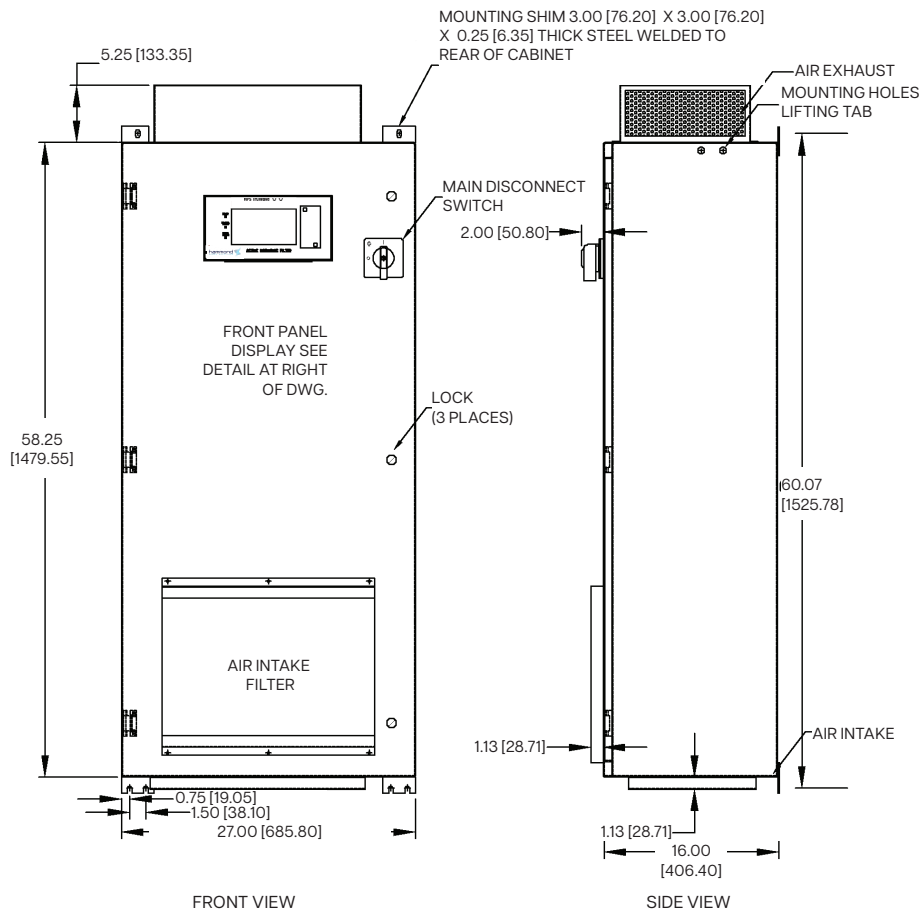

Figure WA2



# ENCLOSURE DRAWINGS

Figure WA3

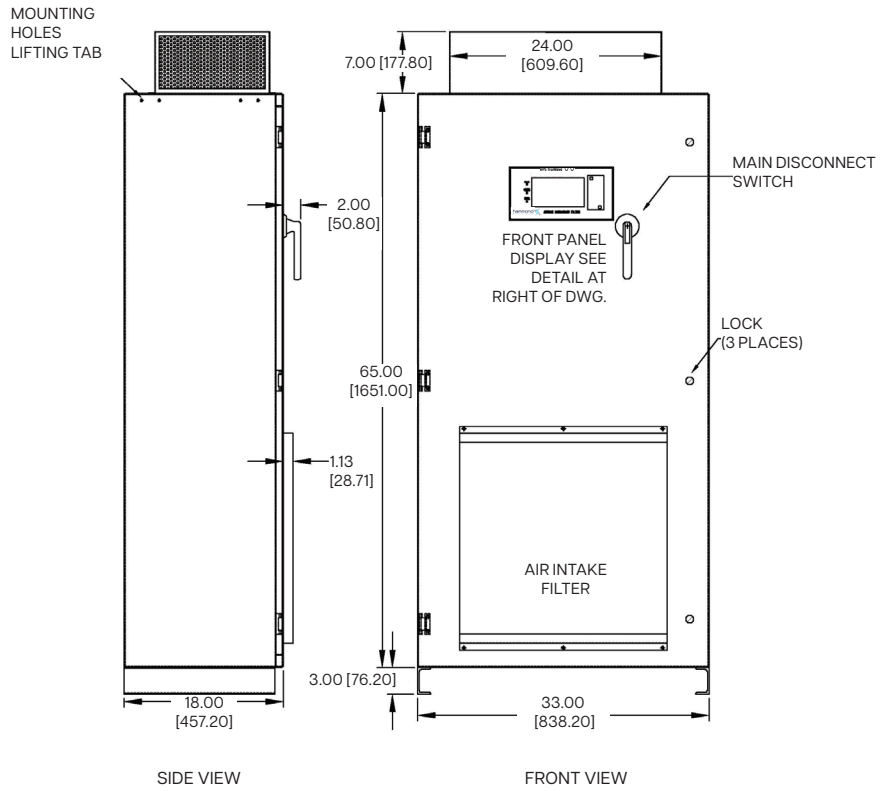
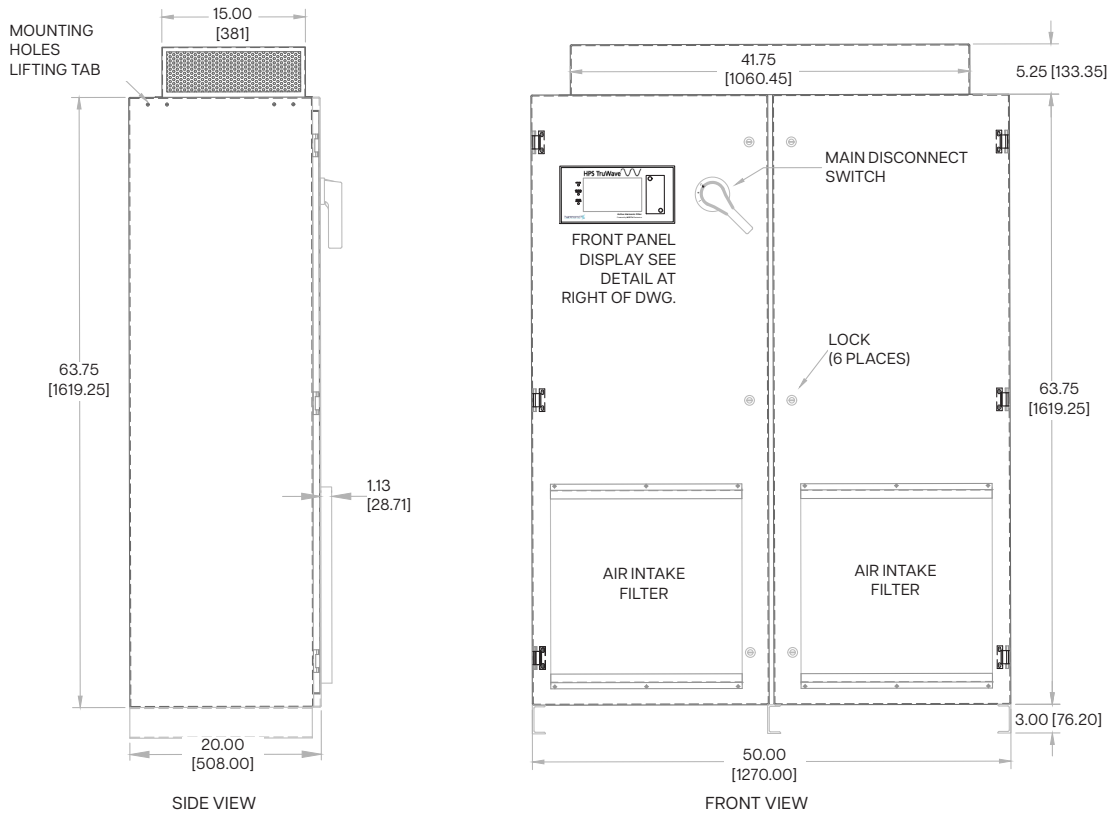
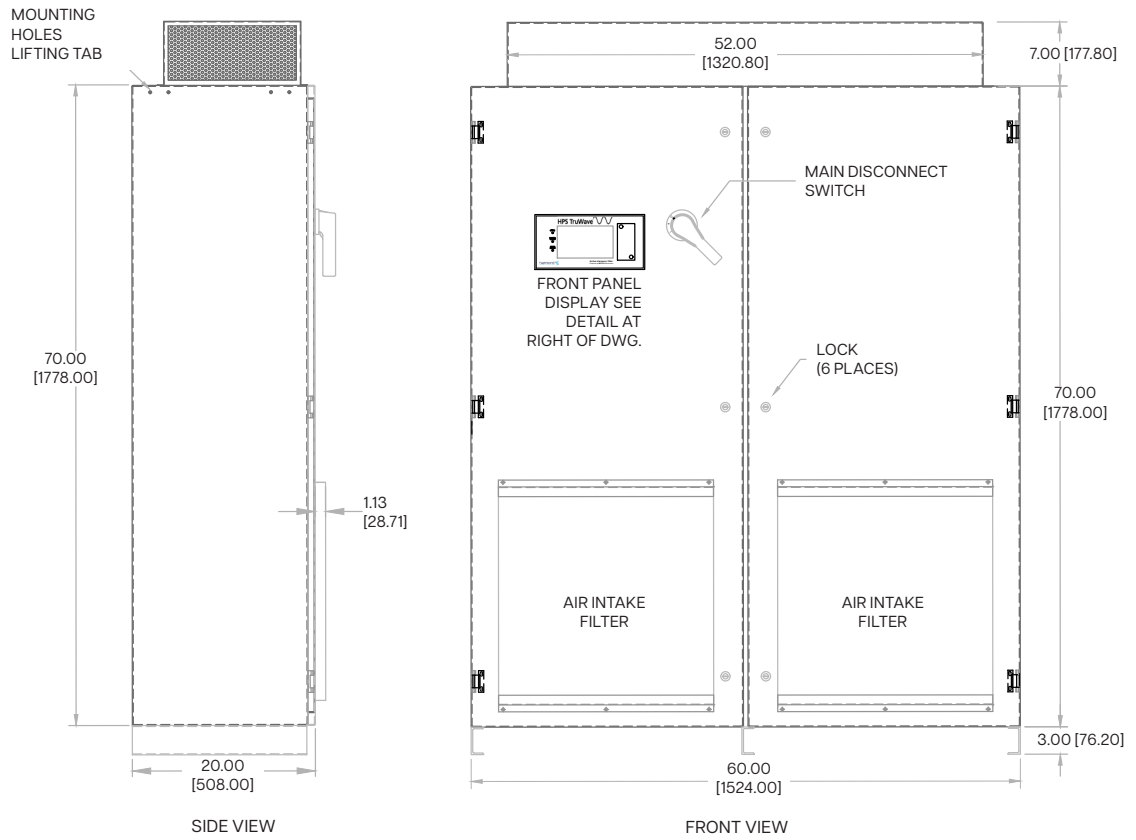

Figure WA4



# ENCLOSURE DRAWINGS

Figure WA5



# FLOOR MOUNTING KIT DRAWINGS

## AHF-FLOOR1 Floor Mount Kit

The following drawings detail the floor mounting dimension required and method by which AHF-FLOOR1 are installed on respective active Harmonics filters (50A & 100A)

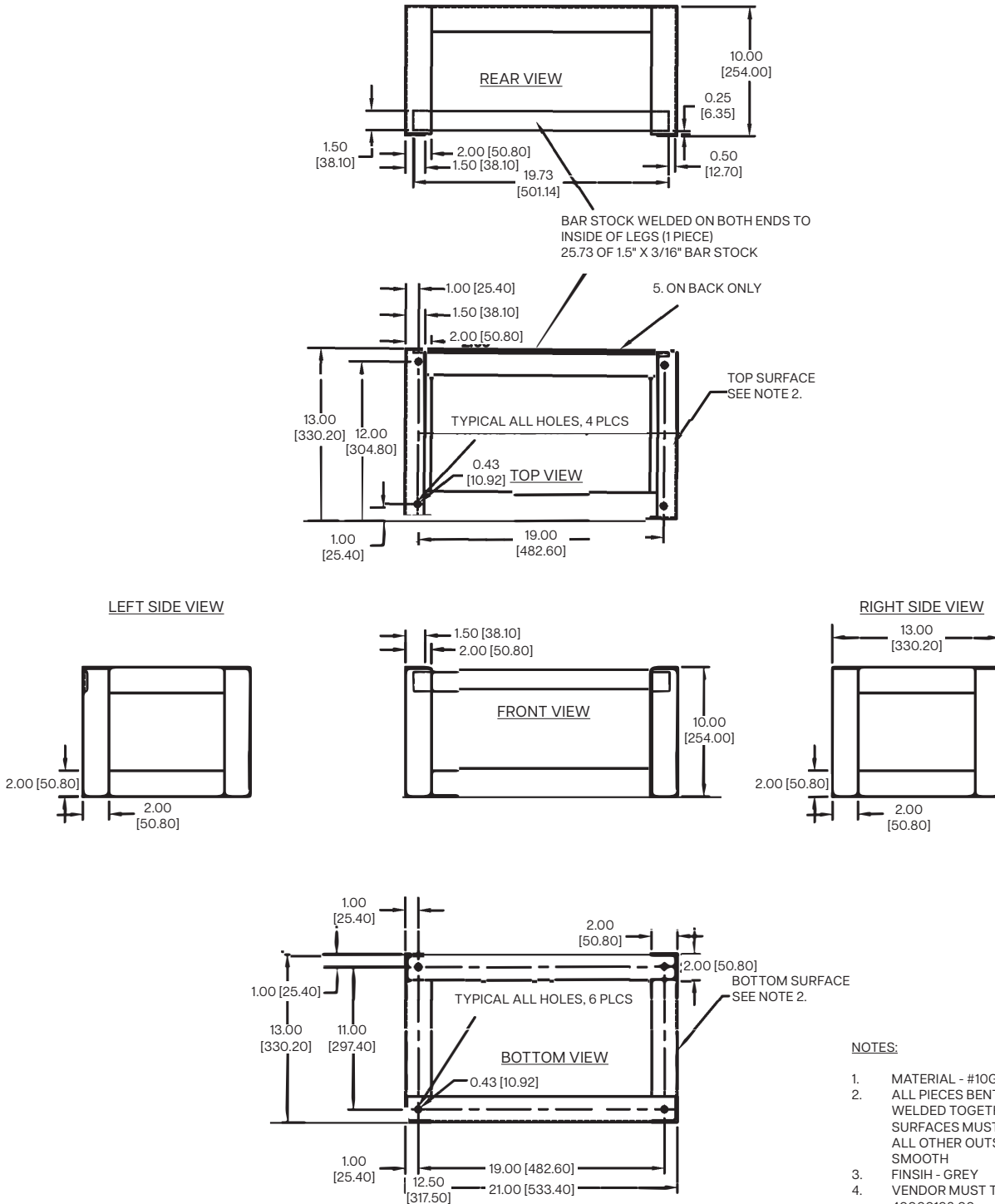

- NOTES:**
1. MATERIAL - #10GA (0.1345"THK CR STEEL)  
ALL PIECES BENT INTO ANGLES. ANGLES WELDED TOGETHER. TOP & BOTTOM SURFACES MUST BE FLAT & SMOOTH. ALL OTHER OUTSIDE SURFACES MUST BE SMOOTH
  2. FINISH - GREY  
VENDOR MUST TAG PART WITH MEST P/N 40000198.00
  3. ON BACK ONLY

# FLOOR MOUNTING KIT DRAWINGS

## AHF-FLOOR2 Floor Mount Kit

The following drawings detail the floor mounting dimension required and method by which AHF-FLOOR1 are installed on respective active Harmonics filters (150A & 200A)

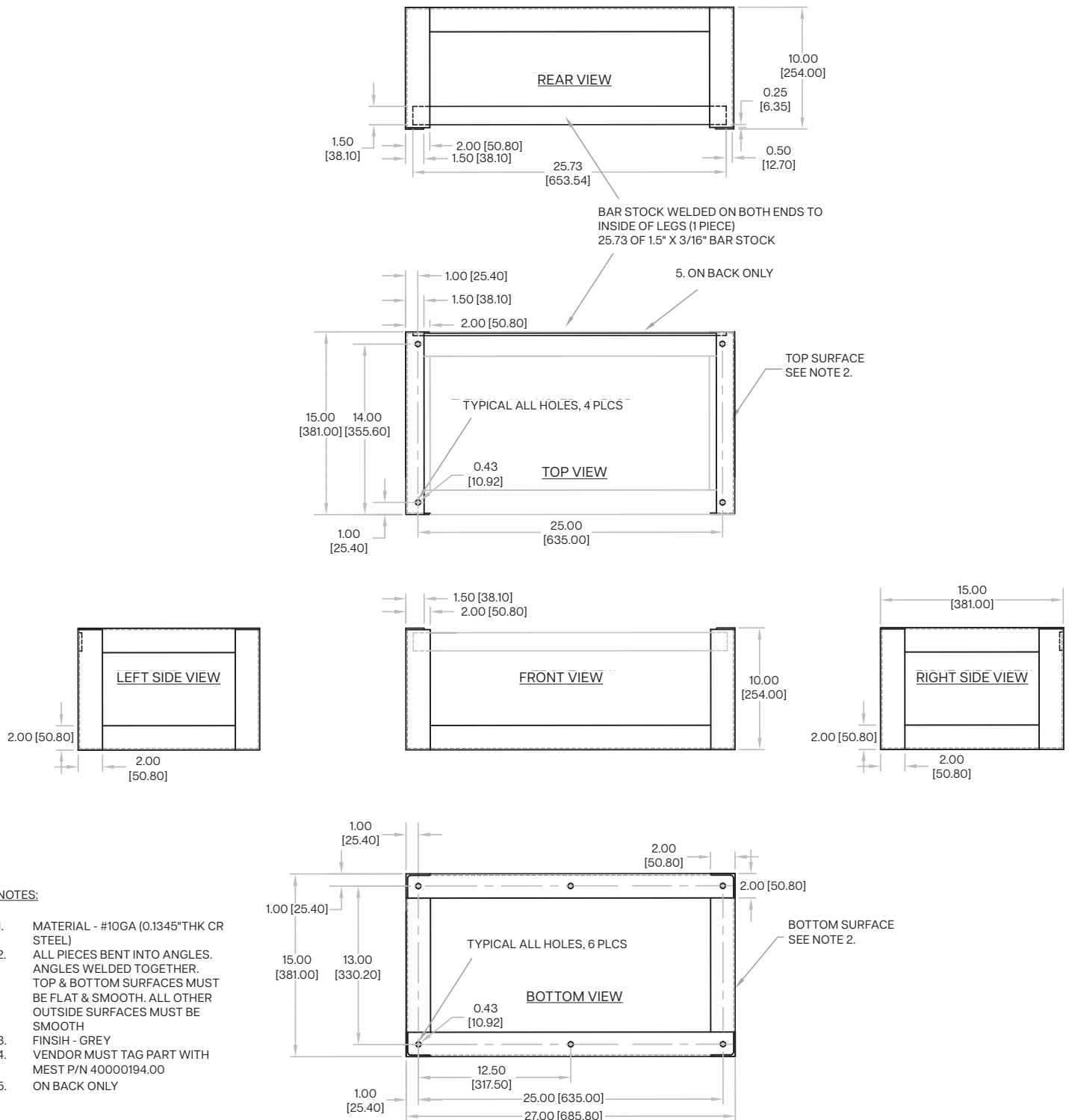

## Other HPS Power Quality Products

HPS has many power quality products which mitigate current and voltage harmonics caused by non-linear loads including rectifiers, variable frequency drives, DC power supplies and E.V. charging.

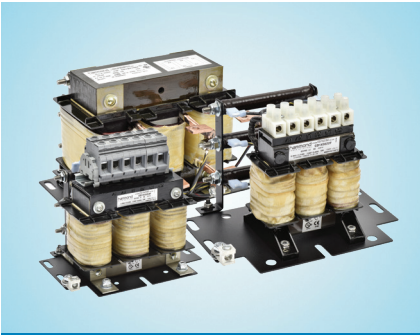

HPS Centurion D1  
dV/dT Filter



HPS Centurion P  
Passive Harmonic Filter



HPS Centurion R  
Reactor



HPS Centurion S  
SineWave Motor Protection Filter



HPS Tribune  
Drive Isolation Transformer



HPS Tribune E  
Drive Isolation Transformer



HPS Sentinel H  
Harmonic Mitigating Transformer

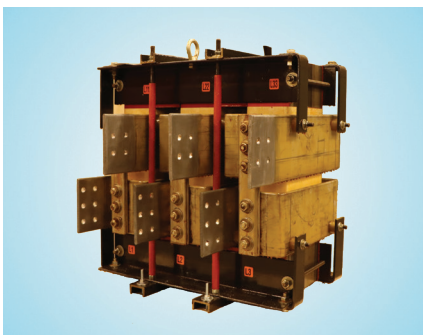

Custom Iron Core  
Reactor



Multi-Pulse  
Medium & Low Voltage



## CANADA

### Hammond Power Solutions

595 Southgate Drive  
Guelph, Ontario N1G 3W6  
Tel: (519) 822-2441 | Fax: (519) 822-9701  
Toll Free: 1-888-798-8882

[sales@hammondpowersolutions.com](mailto:sales@hammondpowersolutions.com)



## UNITED STATES

### Hammond Power Solutions

1100 Lake Street  
Baraboo, Wisconsin 53913-2866  
Tel: (608) 356-3921 | Fax: (608) 355-7623  
Toll Free: 1-866-705-4684

[sales@hammondpowersolutions.com](mailto:sales@hammondpowersolutions.com)



## MEXICO

### Hammond Power Solutions Latin America S.

Av. No. 800,  
Parque Industrial Guadalupe  
Guadalupe, NL, Mexico, C.P. 67190.  
Tel: (819) 690-8000

[sales@hammondpowersolutions.com](mailto:sales@hammondpowersolutions.com)



## ASIA

### Hammond Power Solutions Pvt. Ltd.

Plot No 6A, Phase -1, IDA,  
Pashamylaram, Patancheru (M)  
Sangareddy, 502 307, India  
Tel: +91-994-995-0009

[marketing-india@hammondpowersolutions.com](mailto:marketing-india@hammondpowersolutions.com)

## EMEA (SALES OFFICE)

### Hammond Power Solutions SpA

Tel: +49 (152) 08800468

[sales-emea@hammondpowersolutions.com](mailto:sales-emea@hammondpowersolutions.com)



[hammondpowersolutions.com](http://hammondpowersolutions.com)



TRUWSP-BBH2-EN  
July 2025